

VIRTUAL MAINTENANCE TRAINER

THE NH90 HELICOPTER AS A USE CASE

TECHNICIAN TRAINING FOR SEVEN VARIANTS OF THE NH90

The armed forces in Germany, France, Norway, Sweden and the Netherlands are using our Virtual Maintenance Trainer (VMT) for the training of technicians for their navy and army variants of the NH90. The VMT, together with other training means, largely replaces technician training on real aircrafts. For achieving the training goals, the VMT integrates the simulation of the helicopter systems, a realistic graphical representation of the helicopter and its components as well as training management functions to be able to manage learning progress and to measure the learning success.

DELIVERY

Between 2010 and 2013 the NH90 VMT has been developed on Telespazio and Telespazio Germany sites in Germany and France under a contract with the NATO Helicopter Management Agency (NAHEMA) and in close co-operation with helicopter experts from the user nations. The VMT that is supporting seven variants of the helicopter is used in regular training since late summer 2013.

TRAINING FUNCTIONS

- **Interactive User Interface:** 3D graphics for outer view, cockpit, cabin, bays and rotor, 11000 inter-active areas and five interactive schematics.
- **Traceability:** Recording of accomplished operations, observation of students' lesson handling as well as activation of malfunctions in the virtual helicopter.
- **Computer Guided Mode:** Tracks and assesses a maintenance procedure execution. Trainees have access to context-sensitive help and procedure demonstration.
- **Training Management System Interface:** The NH90's TMS interface assigns tasks to learning groups or individual students and measures learning success.



ADVANTAGES

- **Efficiency:** Using the VMT saves time and costs and improves flexibility, effectiveness and efficiency of training.
- **Cost Reduction:** Integrating the VMT into the overall training curriculum replaces, to a large extent, training on the real helicopter.
- **Flexibility:** Distance training enables a more flexible training plan, without neglecting support from a trainer.
- **Reduced manpower:** In distance learning, complex themes can be imparted with reduced personal effort of instructors through comprehensive training and tools.

CONCEPT

The educational and training objectives include the proficiency in applying the maintenance procedures as well as in utilizing the mission equipment of the navy helicopter variants. For this purpose, the helicopter training system is used together with the Interactive Electronic Technical Publication (IETP). The VMT simulates almost all helicopter subsystems, as far as it is necessary to achieve the training objectives, and supports approx. 450 different complex maintenance and operations tasks. These cover inspection procedures, functional test procedures, adjustment procedures, diagnosis procedures, fault isolation procedures and replace and repair procedures.



DIDACTIC RESOURCES

The VMT networking modes (Demonstration Mode, Student Monitoring Mode and Team Training Mode) in combination with the two training modes (Free Play Mode and Computer Guided Mode) allow an extensive application of the VMT both for self-guided and instructor-led learning.

The recording of procedures by the instructor together with the computer providing guidance to the student during a maintenance or operations procedure (Computer Guided Mode) enables management of training progress and measurement of training success. In Computer Guided Mode, the training system supports the student and calls his attention to mistakes and monitors or evaluates the correct execution of a training session. Furthermore, the network-oriented architecture enables training support from remote sites through distance learning.

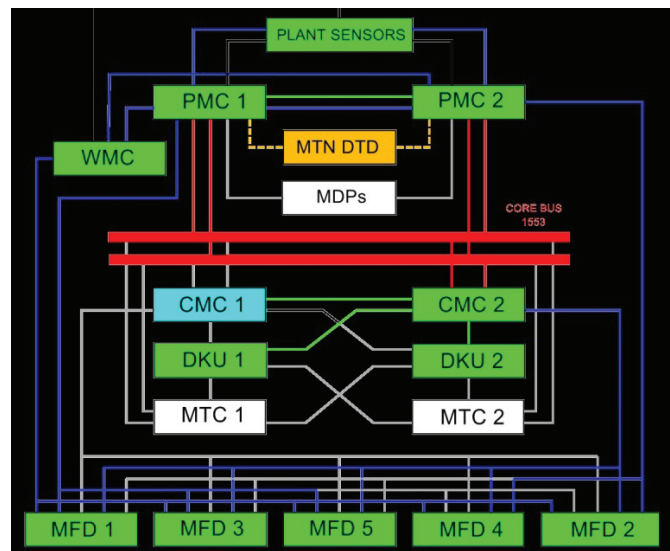

PROPERTIES

The VMT can be launched on laptops or multi-monitor PCs with up to four screens in a stand-alone mode or within a local area or wide area network.

The final version of the NH90 VMT covers training procedures for more than 2200 data modules from the technical publication. A database providing more than 1200 malfunction cases, which can also be combined into more complex malfunction scenarios, serves as a comprehensive basis for a variety of maintenance tasks. For virtual repair, more than 1500 different replaceable parts can be exchanged on the virtual aircraft. In addition, more than 350 different supplies and consumables can be applied for assembly, repair and inspection. More than 500 virtual tools and diagnosis devices (Aircraft Ground Equipment - AGE) allow training diagnosis and repair procedures in the most realistic manner. The functionality of all AGE is fully integrated with the simulation of the helicopter.

